

PORKKA

MEDICAL & SCIENTIFIC
Inventus Medical and Scientific Equipment

Brochure 2026

Inventus Medical and Scientific Cabinets

ENGLISH



FESTIVO-PORKKA GROUP



Inventus Medical & Scientific Equipment

- Excellent product safety for storing temperature-sensitive medicines and storing medicines
 - o High Temperature Protection during defrost period
 - o Anti-freeze protection system (chillers)
 - o The models meet DIN13277 temperature requirements. The temperature uniformity of the product is measured on several different shelf levels. There are five measurement points on each measurement shelf level. The temperature uniformity is the difference between the averages of the minimum and maximum temperatures. The temperature range is the largest temperature difference of the measuring point measured during the measurements.
- Low energy consumption, long life cycle and warranty
 - o Thanks to excellent insulation and vacuum insulation (in some models), energy consumption brings significant savings. Savings in freezer can reach thousands of euros throughout the life cycle of the appliance!
 - o Good isolations and energy-saving components significantly reduce the number of cycles and thus, for example, the compressor's service life is extended. Compressor WARRANTY 5 years for MC and MF models!
 - o Excellent design and high-quality components reduce the need to clean the air filter.
- Hygiene
 - o There are no hard-to-clean holes inside of the cabinet. The shelf guides are drawn to the inside walls of the cabinet, making it very easy to keep the surfaces clean (MC, MF, RC, RF).
 - o There is a pool inside of the cabinet where, due to the breakage of the packaging, liquids can run (all other models except MC/MC8 and MC/MF 8).
 - o Hygiene improving coating for the door handle and control panel.

Inventus Scientific devices bring ease of use and save maintenance costs.

Contents

Inventus 1- door medical chillers and freezers	4
Control unit LED numerical display	5
Inventus MC medical chillers	6
Inventus MF medical freezers	8
Inventus medical chiller and freezer combination cabinets	10
Inventus MC MF accessories	12
Inventus RC RF spark-proof laboratory refrigeration equipment	14
Inventus RC, RF accessories	16
Number of Inventus glass shelves / shelf spacing	18
Inventus flat bottomed plastic storage boxes (accessory)	18
Sales and delivery conditions	19



Inventus MC 7



Inventus MC 7 GW



Inventus 7 MC/MF

Inventus 1-door medical chillers and freezers

Inventus medical chillers and freezers have been designed to improve product safety in temperature sensitive medicins and in medical storage. They are energy-efficient, safe, and reliable. Products are stored in controlled temperatures required by pharmaceutical manufacturers regardless of variations caused by the refrigeration system or normal usage.

Every care has been taken to ensure that high hygienic levels can be maintained, which include rounded corners and a one piece-dished floor pan as well as our integrated shelf supports all of which avoid dirt traps and make the cabinets easy to deep clean. Also pull out / push in door gaskets makes changing easy and quick.

Besides safe surfaces, internal qualities of the product have been developed to meet the requirements of even the most demanding users. Air circulation in the product has been designed to keep the temperature even on all shelves.

Additional product safety is provided by anrifreeze protection in medical chillers, and in freezers by a temperature monitor during defrosting.

The clear interface, quieter operating sound, and environmentally friendly and energy-efficient refrigerant R290 hydrocarbon with a very low Global warming potential (GWP) value make it an ecological choice.



Control unit LED numerical display



All cabinet models feature a clear and easy-to-use control unit.

All main functions can be performed with one push button: checking of the minimum and maximum temperature, continuous on/off recording of temperature, continuous recording of temperature on a USB flash drive.

- Continuous temperature recording
- USB port for data reading
- Big LED number temperature display
- Battery backup for MED SAVE control unit's power failure alarm and temperature recording for 12 hours (with press switch)
- Complies with the DIN 13277 storage requirements
- Temperature monitor during defrost
- Products are available with optional lockable battery backup switch (complies with the requirements DIN 13277 set to storage of pharmaceuticals)
- Versatile features and alarms of MED SAVE control unit are displayed on a large LED screen. If necessary, an acoustic alarm will also produce a sound signal. Potential-free alarm information is transferred to real estate supervision via a control unit. All possible alarms are stored in the memory of the control unit with precise time and alarm information.

Inventus MC medical chillers

Inventus medical chillers have been designed with the needs of hospitals and healthcare institutions in mind as the ideal solution to storing temperature sensitive medicines and vaccines. They are energy efficient, safe and reliable.

The lockable and easy to clean Inventus MC medical chiller standard setup includes four glass shelves adjustable in 56 mm intervals.

Features

- Excellent temperature uniformity measured according to DIN 13277
- The interior meets the Ex classification (II 3 G Ex ec IIB T5 Gc)
Note! Does not apply to cabinets equipped with light
- Low noise level, under 49 dB(A)
- Control unit with clear numeric display for temperature and other functions
- 12-hour battery backup for control unit's power failure alarm and temperature recording (DIN 13277 requirement)
- A hygiene-improving antimicrobial coated controller keyboard
- Real time temperature recording and USB port for data reading
- Key lock on the control unit
- Recording of maximum and minimum temperature
- Visual and audible high/low temperature alarm
- Door switch for fan control and door open-alarms
- Probe failure alarm
- Readiness for RS485 adapter for computer connection
- Potential free (no voltage) alarm coupling readiness for real estate monitoring
- 50 ml bottle for a temperature sensor P4 inside the cabinet
- Fan assisted air distribution
- Anti-freeze protection
- Automatic defrost
- High Temperature Protection during defrost period
- Automatic vaporization of condensed water
- Molded eco-friendly polyurethane insulated frame. The insulation thickness is 80-100 mm
- The visible external finish has a white polyester coated sheet steel or stainless steel. Interior finish in stainless steel
- 4 glass shelves (maximum load 50 kg / shelf) which are adjustable in increments of 56 mm
- Abloy lock is placed in front panel for easy maintenance (Abloy Sentry key)
- The self-closing door has a sturdy molded handle, magnetic seal, and durable hinges. The door remains open at a 90 degree angle
- A hygiene-improving antimicrobial coated handle is designed as a solid part of the door
- Stainless steel legs, height adjustable from 130 mm to 205 mm
- Efficient, environmental friendly, energy saving R290 refrigerant
- Electrical supply 230V / 50 Hz



Accessories

- Additional shelves
- Wire basket
- Plastic storage box set
- Castors, lockable front castors
- Shorter stainless steel legs, adjustable from 80 mm to 105 mm
- Door opening pedal
- ø 8 mm sleeved access port for additional probe
- LED light (standard in GW models)
- iLOQ lock (Abloy as a standard)
- DIN accessory package (lockable battery backup switch)

Inventus MC medical chillers

Inventus			MC 6	MC 7	MC 8	MC 6 GW	MC 7 GW	MC 8 GW
External dimensions	Width	mm	600	730	850	600	730	850
	Depth	mm	760	870	750	760	870	750
	Height	mm	2100	2100	2100	2100	2100	2100
Internal dimensions	Width *	mm	404	534	654	404	534	654
	Depth	mm	610	675	555	610	675	555
	Height	mm	1485	1485	1485	1485	1485	1485
Volume (measured on a SS shelf according to DIN standard)	Net	liters	331	489	491	331	489	491
	Gross	liters	421	609	619	421	609	619
Weight	Net	kg	120	135	140	133	152	144
Package weight	Gross	kg	129	145	150	142	162	154
Package size	Width	mm	650	780	900	650	780	900
	Depth	mm	800	920	800	800	920	800
	Height	mm	2250	2250	2250	2250	2250	2250
Sound level measured at the distance of 1m and from the height of 1.6 m		dB	49	49	49	49	49	49
Operating temperature		°C	+2...+15 °C	+2...+15 °C	+2...+15 °C	+2...+15 °C	+2...+15 °C	+2...+15 °C
Ambient temperature		°C	+10...+35 °C	+10...+35 °C	+10...+35 °C	+10...+35 °C	+10...+35 °C	+10...+35 °C
Temperature uniformity / fluctuation (please see the page 2 DIN 13277)		°C	0,8 / 1,7	0,7 / 1,8	0,9 / 2,3	1,7 / 2,1	1,6 / 2,1	1,7 / 2,6
Refrigerant	(g)/GWP	g	R290/115 g (GWP 3)	R290/110 g (GWP 3)	R290/110 g (GWP 3)	R290/115 g (GWP 3)	R290/110 g (GWP 3)	R290/110 g (GWP 3)
Connection Power		kW	0,5	0,5	0,5	0,5	0,5	0,5
Fuse	Slow	A	10	10	10	10	10	10
Voltage		V	230/50 Hz	230/50 Hz	230/50 Hz	230/50 Hz	230/50 Hz	230/50 Hz
Defrost			Off-cycle	Off-cycle	Off-cycle	Off-cycle	Off-cycle	Off-cycle
Energy consumption (GW LED light OFF/ON)		kWh/year	203	256	270	350	372	409
Energy consumption (GW LED light OFF/ON)		kWh/d	0,557	0,7	0,74	0,96	1,02	1,12
Shelves (width x depth)		mm	400 x 600	530 x 650	650 x 530	400 x 600	530 x 650	650 x 530
Shelf amount standard/maximum		pcs	4 / 24	4 / 24	4 / 24	4 / 24	4 / 24	4 / 24

* Free width = shelf width -20 mm



Inventus MC 6

Inventus MC 7

Inventus MC 8

Inventus MC 6 GW

Inventus MC 7 GW

Inventus MC 8 GW

Inventus MF medical freezers

Inventus medical freezers have been designed with the needs of hospitals and healthcare institutions in mind as the ideal solution to storing temperature sensitive medicines. They are energy efficient, safe and reliable.

The lockable and easy to clean Inventus MF medical freezer standard setup includes four glass shelves adjustable in 56 mm intervals.

Inventus medical freezers have an automatic defrosting functionality with an excellent steadiness of temperature uniformity.

Features

- Excellent temperature uniformity measured according to DIN 13277
- The interior meets the Ex classification (II 3 G Ex ec IIB T5 Gc)
Note! Does not apply to cabinets equipped with light
- Low noise level, under 50 dB(A)
- Control unit with clear numeric display for temperature and other functions
- 12-hour battery backup for control unit's power failure alarm and temperature recording (DIN 13277 requirement)
- A hygiene-improving antimicrobial coated controller keyboard
- Real time temperature recording and USB port for data reading
- Key lock on the control unit
- Recording of maximum and minimum temperature
- Visual and audible high/low temperature alarm
- Door switch for fan control and door open-alarms
- Probe failure alarm
- Readiness for RS485 adapter for computer connection
- Potential free (no voltage) alarm coupling readiness for real estate monitoring
- 50 ml bottle for a temperature sensor P4 inside the cabinet
- Fan assisted air distribution
- Automatic defrost
- High Temperature Protection during defrost period
- Automatic vaporization of condensed water
- Molded eco-friendly polyurethane insulated frame.
The insulation thickness is 80-100 mm
- The visible external finish has a white polyester coated sheet steel or stainless steel. Interior finish in stainless steel
- 4 glass shelves (maximum load 50 kg / shelf) which are adjustable in increments of 56 mm
- Abloy lock is placed in front panel for easy maintenance (Abloy Sentry key)
- The self-closing door has a sturdy molded handle, magnetic seal, and durable hinges. The door remains open at a 90 degree angle
- A hygiene-improving antimicrobial coated handle is designed as a solid part of the door
- Stainless steel legs, height adjustable from 130 mm to 205 mm
- Efficient, environmental friendly, energy saving R290 refrigerant
- Electrical supply 230V / 50 Hz

Accessories

- Additional shelves
- Wire basket
- Flat bottomed plastic storage box set
- Castors, lockable front castors
- Short stainless steel legs, adjustable from 80 mm to 105 mm
- Door opening pedal
- Ø 8 mm sleeved access port for additional probe
- LED light
- iLOQ lock (Abloy as a standard)
- DIN accessory package (lockable battery backup switch)

Inventus MF medical freezers

Inventus			MF 6	MF 7	MF 8
External dimensions	Width	mm	600	730	850
	Depth	mm	760	870	750
	Height	mm	2100	2100	2100
Internal dimensions	Width *	mm	404	534	654
	Depth	mm	610	675	555
	Height	mm	1485	1485	1485
Volume (measured on a SS shelf according to DIN standard)	Net	liters	331	489	491
	Gross	liters	421	609	619
Weight	Net	kg	125	156	138
Package weight	Gross	kg	136	166	148
Package size	Width	mm	650	780	900
	Depth	mm	800	920	800
	Height	mm	2250	2250	2250
Sound level measured at the distance of 1m and from the height of 1.6 m		dB	50	50	50
Operating temperature		°C	-26...-15 °C	-26...-15 °C	-26...-15 °C
Ambient temperature		°C	+10...+35 °C	+10...+35 °C	+10...+35 °C
Temperature uniformity / fluctuation (please see the page 2 DIN 13277)		°C	1,6 / 2	1,6 / 2,2	1,7 / 2,7
Refrigerant	(g)/GWP	g	R290/83 g (GWP 3)	R290/90 g (GWP 3)	R290/90 g (GWP 3)
Connection Power		kW	0,5	0,5	0,5
Fuse	Slow	A	10	10	10
Voltage		V	230V/50Hz	230V/50Hz	230V/50Hz
Defrost			Hot gas	Hot gas	Hot gas
Energy consumption (GW LED light OFF/ON)		kWh/year	837	865	894
Energy consumption (GW LED light OFF/ON)		kWh/d	2,293	2,37	2,45
Shelves (width x depth)		mm	400 x 600	530 x 650	650 x 530
Shelf amount standard/maximum		pcs	4 / 24	4 / 24	4 / 24

* Free width = shelf width -20 mm



Inventus MF 6



Inventus MF 7



Inventus MF 8

Inventus medical chiller and freezer combination cabinets

Inventus medical chiller and freezer combination cabinets have been designed with the needs of hospitals and healthcare institutions in mind as the ideal solution to storing temperature sensitive medicines and vaccines. They are energy efficient, safe and reliable.

The lockable and easy to clean Inventus medical combination cabinets standard setup includes four glass shelves adjustable in 30 mm intervals.

Features

- Excellent temperature uniformity measured according to DIN 13277.
- The interior meets the Ex classification (II 3 G Ex ec IIB T5 Gc)
Note! Does not apply to cabinets equipped with light
- Low noise level, under 50 dB(A)
- Control unit with clear numeric display for temperature and other functions
- 12-hour battery backup for control unit's power failure alarm and temperature recording (DIN 13277 requirement)
- A hygiene-improving antimicrobial coated controller keyboard
- Real-time temperature data recording and reading to USB memory in both compartments
- Key lock on the control unit
- Recording of maximum and minimum temperature
- Visual and audible high/low temperature alarm
- Door switch for fan control and door open-alarms
- Probe failure alarm
- Readiness for RS485 adapter for computer connection
- Potential free (no voltage) alarm coupling readiness for real estate monitoring
- 50 ml bottle for a temperature sensor P4 inside the

- cabinet
- Ø 8 mm sleeved access port for additional probe as standard in both compartments
- Fan assisted air distribution
- Anti-freeze protection (MC)
- Automatic defrost
- High Temperature Protection during defrost period
- Automatic vaporization of condensed water
- Molded eco-friendly polyurethane insulated frame. The insulation thickness is 80-100 mm
- The visible external finish has a white polyester coated sheet steel or stainless steel. Interior finish in stainless steel
- 2+2 glass shelves (maximum load 50 kg / shelf) which are adjustable in increments of 30 mm
- Abloy lock is placed in middle panel for easy maintenance (Abloy Sentry key). The lock has a double latch that locks both doors at the same time
- The self-closing door has a sturdy molded handle, magnetic seal, and durable hinges. The door remains open at a 90 degree angle
- A hygiene-improving antimicrobial coated handle is designed as a solid part of the door
- Stainless steel legs, height adjustable from 130 mm to 205 mm
- Efficient, environmental friendly, energy saving R290 refrigerant
- Electrical supply 230V - 50 / 60 Hz



Inventus 7 MC/MF

Accessories

- Additional shelves
- Wire basket
- Plastic storage box set
- Castors, lockable front castors
- Shorter stainless steel legs, adjustable from 80 mm to 105 mm
- LED light
- iLOQ lock placed in middle panel (Abloy as standard)
- DIN accessory package (lockable battery backup switch)

Inventus medical chiller and freezer combination cabinets

Inventus			MC/MC 7 chiller / chiller		MC/MF 7 chiller / freezer		MC/MC 8 chiller / chiller		MC/MF 8 chiller / freezer	
			UPPER MC	LOWER MC	UPPER MC	LOWER MF	UPPER MC	LOWER MC	UPPER MC	LOWER MF
External dimensions	Width	mm	730		730		850		850	
	Depth	mm	870		870		750		750	
	Height	mm	2100		2100		2100		2100	
Internal dimensions	Width	mm	534	534	534	534	654	654	654	654
	Depth	mm	675/450	675/450	675/450	675/450	555/300	555/300	555/300	300
	Height	mm	650/505	745/600	650/505	745/600	650/505	745/600	650/505	745/600
Volume (measured on a SS shelf according to DIN standard)	Net	liters	188	220	188	220	184	216	184	216
	Gross	liters	218	251	218	251	218	251	218	251
Total volume net/gross		liters	469/410		469/410		469/402		469/402	
Weight	Net	kg	149		150		149		150	
Package weight	Gross	kg	159		160		159		160	
Package size	Width	mm	780		780		900		900	
	Depth	mm	920		920		800		800	
	Height	mm	2250		2250		2250		2250	
Sound level measured at the distance of 1m and from the height of 1.6 m		dB	< 50		< 50		< 50		< 50	
Operating temperature		°C	+2...+15 °C	+2...+15 °C	+2...+15 °C	-26...-15 °C	+2...+15 °C	+2...+15 °C	+2...+15 °C	-26...-15 °C
Ambient temperature		°C	+10...+35 °C		+10...+35 °C		+10...+35 °C		+10...+35 °C	
Temperature uniformity / fluctuation (please see the page 2 DIN 13277)		°C	0,6 / 1,35		0,6 / 1,35	0,8 / 2,8	0,6 / 1,35		0,6 / 1,35	0,8 / 2,8
Refrigerant	(g)/GWP	g	R290/100 g (GWP 3)	R290/100 g (GWP 3)	R290/100 g (GWP 3)	R290/90 g (GWP 3)	R290/100 g (GWP 3)	R290/100 g (GWP 3)	R290/100 g (GWP 3)	R290/90 g (GWP 3)
Connection Power		kW	0,3		0,42		0,3		0,42	
Fuse	Slow	A	10		10		10		10	
Voltage			230 V - 50/60 Hz		230 V - 50/60 Hz		230 V - 50/60 Hz		230 V - 50/60 Hz	
Defrost			Off-cycle	Off-cycle	Off-cycle	Hot gas	Off-cycle	Off-cycle	Off-cycle	Hot gas
Energy consumption (GW LED light OFF/ON)		kWh/year	592		1248		592		1248	
Energy consumption (GW LED light OFF/ON)		kWh/d	1,623		3,419		1,623		3,419	
Shelves (width x depth)		mm	530 x 650		530 x 650		650 x 530		650 x 530	
Shelf amount standard/maximum		pcs	2 / 5	2 / 5	2 / 5	2 / 5	2 / 5	2 / 5	2 / 5	2 / 5



Inventus MC MF factory installed accessories

APF19010	Ø 8 MM SLEEVED ACCESS PORT FOR ADDITIONAL PROBE (ADDITION TO INSTALLATION DEPTH: MODEL 6 +25 MM, MODELS 7 AND 8 +35 MM) NOTE! STANDARD ON MC/MC AND MC/MF MODELS
APF19022	PROBE PT100 TF14 (CABLE 3 M) FOR REMOTE TEMPERATURE MONITORING
APC12030	JUNCTION BOX AND CONNECTED ALARM CABLE (2.5 M) WITH RJ45 PLUG
APF19021	CENTRAL ALARM JUNCTION BOX
APC12100	TTL/RS-485 DATA CABLE 0.5 M / DEPARTMENT
APC12300	GROUNDING CABLE
APF19020	DIN ACCESSORY PACKAGE (LOCKABLE BATTERY BACKUP SWICTH)
APF19000	ELECTRONIC LOCK iLOQ S10 + ONE KEY Further information: www.iloq.com
APM20605	iLOQ S10 ADDITIONAL KEY Further information: www.iloq.com
APF19001	ELECTRONIC LOCK iLOQ S5 + ONE KEY Further information: www.iloq.com
6300221	iLOQ S5 ADDITIONAL KEY Further information: www.iloq.com
API10130	ELECTRONIC LOCK iLOQ S10 DOUBLE LATCH + ONE KEY Further information: www.iloq.com (NOTE! COMBINATION CABINETS)
API10131	ELECTRONIC LOCK iLOQ S5 DOUBLE LATCH + ONE KEY Further information: www.iloq.com (NOTE! COMBINATION CABINETS)
APF10320	STAINLESS STEEL PANEL SHELF 6
API10103	STAINLESS STEEL WIRE SHELF 6
API10112	GLASS SHELF 6
API10106	STAINLESS STEEL BOTTOM WIRE SHELF 6
APF10520	STAINLESS STEEL PANEL SHELF 7
API10104	STAINLESS STEEL WIRE SHELF 7
API10113	GLASS SHELF 7
API10107	STAINLESS STEEL BOTTOM WIRE SHELF 7
APF11020	STAINLESS STEEL WIRE BASKET 7
APF10420	STAINLESS STEEL PANEL SHELF 8
API10105	STAINLESS STEEL WIRE SHELF 8
API10114	GLASS SHELF 8
API10108	STAINLESS STEEL BOTTOM WIRE SHELF 8
APF10970	STAINLESS STEEL WIRE BASKET 8
APF19032	FLAT BOTTOMED PLASTIC STORAGE BOX 6, ONE SHELF SET 150 x 600 x 90 MM (2 PCS)
APF19031	FLAT BOTTOMED PLASTIC STORAGE BOX 7, ONE SHELF SET 230 x 600 x 90 MM (2 PCS)
APF19030	FLAT BOTTOMED PLASTIC STORAGE BOX 8, ONE SHELF SET 230 x 500 x 90 MM (2 PCS) + 150 x 500 x 90 MM (1 PCS)
API10092	HYGIENIC ROOFING 6
API10093	HYGIENIC ROOFING 7
API10094	HYGIENIC ROOFING 8
API10090	HYGIENIC ROOFING C/C AND C/F 7
API10091	HYGIENIC ROOFING C/C AND C/F 8
APF16600	LED LIGHT (1-DOOR CABINETS)
API20103	LED LIGHTS UPPER AND LOWER CABINET (2-DOORS CABINETS)
APF13800	CASTORS, LOCKABLE FRONT CASTORS WHEN CABINET HEIGHT = 2080 MM
APF13200	SHORT STAINLESS STEEL LEGS, ADJUSTABLE FROM 80 MM TO 105 MM WHEN CABINET HEIGHT = 2050 MM
APF12400	DOOR OPENING PEDAL (NOTE! C/C AND C/F LOWER DOOR ONLY)
APF19040	HYGIENE IMPROVING COATING WITH DISINFECTING LIGHT
APF19041	HYGIENE IMPROVING COATING WITH DISINFECTING LIGHT (GW MODELS)
API10050	HDR TEMPERATURE RANGE +2...+6 °C (MC)

Inventus MC MF factory installed accessories



JUNCTION BOX AND CONNECTED ALARM CABLE (2.5 M) WITH RJ45 PLUG



CENTRAL ALARM JUNCTION BOX



TTL/RS-485 DATA CABLE 0.5 M



iLOQ LOCK



STAINLESS STEEL PANEL SHELF



STAINLESS STEEL WIRE SHELF



GLASS SHELF



STAINLESS STEEL WIRE BASKET



FLAT BOTTOMED PLASTIC STORAGE BOX



HYGIENIC ROOFING



LED LIGHT



CASTORS



SHORT STAINLESS STEEL LEGS



DOOR OPENING PEDAL

Inventus RC and RF spark-proof laboratory refrigeration equipment

Inventus RC ja RF research and test cabinets have been designed for laboratories, health care and biosciences.

**SPARK
PROOF
INTERIOR**

Standard setups of lockable and easy to clean Inventus RC and RF cabinets include four glass shelves adjustable in 56 mm intervals.

Features

- Excellent temperature uniformity ($\pm 1^{\circ}\text{C}$) measured from 100 g mass
- The interior meets the Ex classification (II 3 G Ex ec IIB T5 Gc)
Note! Does not apply to cabinets equipped with light
- Low noise level, under 49 dB(A)
- Control unit with clear numeric display for temperature and other functions
- 12-hour battery backup for control unit's power failure alarm and temperature recording
- A hygiene-improving antimicrobial coated controller keyboard
- Real time temperature recording and USB port for data reading
- Key lock on the control unit
- Recording of maximum and minimum temperature
- Visual and audible high/low temperature alarm
- Door switch for fan control and door open-alarms
- Probe failure alarm
- Readiness for RS485 adapter for computer connection
- Potential free (no voltage) alarm coupling readiness for real estate monitoring
- 50 ml bottle for a temperature sensor P4 inside the cabinet
- Fan assisted air distribution
- Automatic defrost
- Overheat protection (RC)
- Automatic vaporization of condensed water
- Molded eco-friendly polyurethane insulated frame. The insulation thickness is 80-100 mm
- The visible external finish has a white polyester coated sheet steel or stainless steel. Interior finish in stainless steel
- 4 glass shelves are adjustable in increments of 56 mm
- Abloy lock is placed in front panel for easy maintenance (Abloy Sentry key)
- The self-closing door has a sturdy molded handle, magnetic seal, and durable hinges. The door remains open at a 90 degree angle
- A hygiene-improving antimicrobial coated handle is designed as a solid part of the door
- Stainless steel legs, height adjustable from 130 mm to 205 mm
- Efficient, environmental friendly, energy saving R290 refrigerant
- Electrical supply 230V / 50 Hz



Accessories

- Additional shelves
- Flat bottomed plastic storage box set
- Stainless steel wire basket
- Castors, lockable front castors
- Short stainless steel legs, adjustable from 80 mm to 105 mm
- Door opening pedal
- $\varnothing 8$ mm sleeved access port for additional probe
- LED light (standard in GW models)
- iLOQ lock (Abloy as a standard)

Inventus RC and RF spark-proof laboratory refrigeration equipment

Inventus			RC 6	RC 8	RC 6 GW	RC 8 GW	RF 6	RF 8
External dimensions	Width	mm	600	850	600	850	600	850
	Depth	mm	760	750	760	750	760	750
	Height	mm	2100	2100	2100	2100	2100	2100
Internal dimensions	Width	mm	404	654	404	654	404	654
	Depth	mm	610	555	610	555	610	555
	Height	liters	1485	1485	1485	1485	1485	1485
Volume (measured according to DIN standard)	Net	liters	331	491	331	491	331	491
	Gross	kg	421	619	421	619	421	619
Weight	Net	kg	132	145	137	157	126	156
Package weight	Gross	mm	142	155	147	167	135	166
Package size	Width	mm	650	900	650	900	650	900
	Depth	mm	800	800	800	800	800	800
	Height	mm	2250	2250	2250	2250	2250	2250
Sound level measured at the distance of 1m / from the height of 1.6 m		dB	49	49	49	49	50	50
Operating temperature		°C	+2...+40 °C	+2...+40°C	+2...+40 °C	+2...+40°C	-32...-15 °C	-32...-15 °C
Ambient temperature		°C	+10...+35 °C	+10...+35 °C	+10...+35 °C	+10...+35 °C	+10...+35 °C	+10...+35 °C
Temperature accuracy (measured with 100 g mass)		°C	±1	±1	±1	±1	±1	±1
Refrigerant	(g)/GWP	g	R290/115 g (GWP 3)	R290/110 g (GWP 3)	R290/115 g (GWP 3)	R290/110 g (GWP 3)	R290/83 g (GWP 3)	R290/90 g (GWP 3)
Connection Power		kW	0,5	0,5	0,5	0,5	0,65	0,75
Fuse	Slow	A	10	10	10	10	10	10
Voltage		V	230/50 Hz	230/50 Hz	230/50 Hz	230/50 Hz	230V/50Hz	230V/50Hz
Defrost			Off-cycle	Off-cycle	Off-cycle	Off-cycle	Hot gas	Hot gas
Energy consumption		kWh/year	1641	1656	1752	1174	2263	2592
Energy consumption		kWh/d	4,497	4,537	4,799	4,859	6,2	7,1
Shelves (width x depth)		mm	400 x 600	650 x 530	400 x 600	650 x 530	400 x 600	650 x 530
Shelf amount standard/maximum		pcs	4 / 24	4 / 24	4 / 24	4 / 24	4 / 24	4 / 24



Inventus RC 6, RF 6



Inventus RC 8, RF 8



Inventus RC 6 GW



Inventus RC 8 GW

Inventus RC and RF factory installed accessories

APF19010	Ø 8 MM SLEEVED ACCESS PORT FOR ADDITIONAL PROBE (ADDITION TO INSTALLATION DEPTH: MODEL 6 +25 MM, MODEL 8 +35 MM)
APF19022	PROBE PT100 TF14 (CABLE 3 M)
APC13010	ANTI-FREEZE PROTECTION (RC)
APC12030	JUNCTION BOX AND CONNECTED ALARM CABLE (2.5 M) WITH RJ45 PLUG
APF19021	CENTRAL ALARM JUNCTION BOX
APC12100	TTL/RS-485 DATA CABLE 0.5 M
APC12300	GROUNDING CABLE
APF19000	ELECTRONIC LOCK iLOQ S10 (INCLUDES ONE KEY)
APM20605	iLOQ S10 ADDITIONAL KEY
APF19001	ELECTRONIC LOCK iLOQ S5+ ONE KEY Further information: www.iloq.com
API10203	iLOQ S5 ADDITIONAL KEY Further information: www.iloq.com
APF10320	STAINLESS STEEL PANEL SHELF 6
API10103	STAINLESS STEEL WIRE SHELF 6
API10112	GLASS SHELF 6
API10106	STAINLESS STEEL BOTTOM WIRE SHELF 6
APF10420	STAINLESS STEEL PANEL SHELF 8
API10105	STAINLESS STEEL WIRE SHELF 8
API10114	GLASS SHELF 8
API10108	STAINLESS STEEL BOTTOM WIRE SHELF 8
APF10970	STAINLESS STEEL WIRE BASKET 8
APF19032	FLAT BOTTOMED PLASTIC STORAGE BOX 6, ONE SHELF SET 150 x 600 x 90 MM (2 PCS)
APF19030	FLAT BOTTOMED PLASTIC STORAGE BOX 8, ONE SHELF SET 230 x 500 x 90 MM (2 PCS) + 150 x 500 x 90 MM (1 PCS)
API10092	HYGIENIC ROOFING 6
API10094	HYGIENIC ROOFING 8
APF16600	LED LIGHT
APF13800	CASTORS, LOCKABLE FRONT CASTORS WHEN CABINET HEIGHT = 2080 MM
APF13200	SHORT STAINLESS STEEL LEGS, ADJUSTABLE FROM 80 MM TO 105 MM WHEN CABINET HEIGHT = 2050 MM
APF12400	DOOR OPENING PEDAL
APF19040	HYGIENE IMPROVING COATING WITH DISINFECTING LIGHT
APF19041	HYGIENE IMPROVING COATING WITH DISINFECTING LIGHT (GW MODELS)
API10051	HDF TEMPERATURE RANGE -32...-27 °C (RF)

Inventus RC and RF factory installed accessories



JUNCTION BOX AND CONNECTED ALARM CABLE (2.5 M) WITH RJ45 PLUG



CENTRAL ALARM JUNCTION BOX



TTL/RS-485 DATA CABLE 0.5 M



iLOQ LOCK



STAINLESS STEEL PANEL SHELF



STAINLESS STEEL WIRE SHELF



GLASS SHELF



STAINLESS STEEL WIRE BASKET 8



FLAT BOTTOMED PLASTIC STORAGE BOX



HYGIENIC ROOFING



LED LIGHT



CASTORS



SHORT STAINLESS STEEL LEGS



DOOR OPENING PEDAL

Number of Inventus glass shelves / shelf spacing

GLASS SHELVES AMOUNT / CABINET	MAXIMUM STORAGE HEIGHT BETWEEN SHELVES
4 (standard amount)	327 mm
5	215 mm
8	159 mm
12	103 mm
24	47 mm

* Shelf bracket space 56 mm

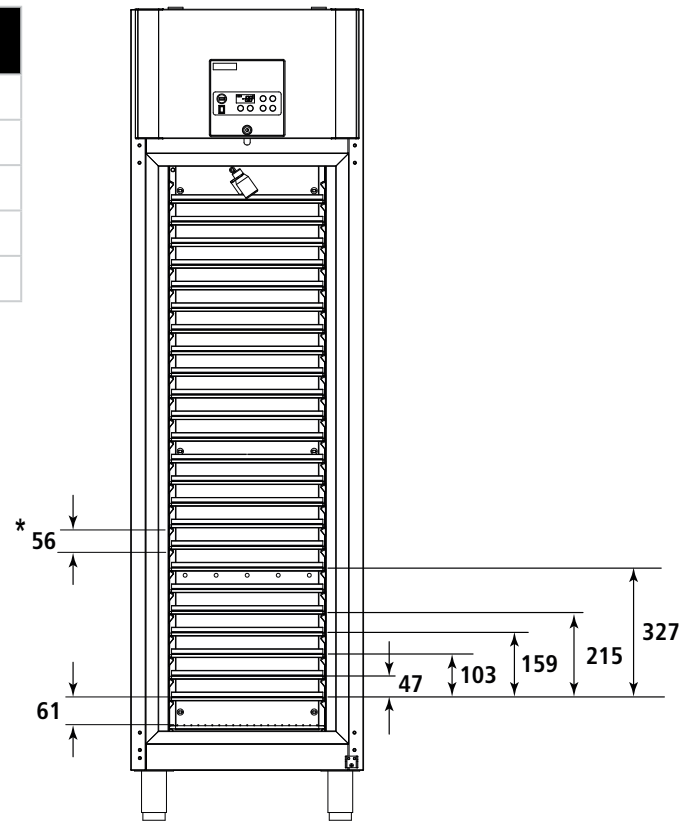

Inventus flat bottomed plastic storage boxes (accessory)

APF19032	FLAT BOTTOMED PLASTIC STORAGE BOX 6, ONE SHELF SET 150 x 600 x 90 MM (2 PCS)
APF19031	FLAT BOTTOMED PLASTIC STORAGE BOX 7, ONE SHELF SET 230 x 600 x 90 MM (2 PCS)
APF19030	FLAT BOTTOMED PLASTIC STORAGE BOX 8, ONE SHELF SET 230 x 500 x 90 MM (2 PCS) + 150 x 500 x 90 MM (1 PCS)

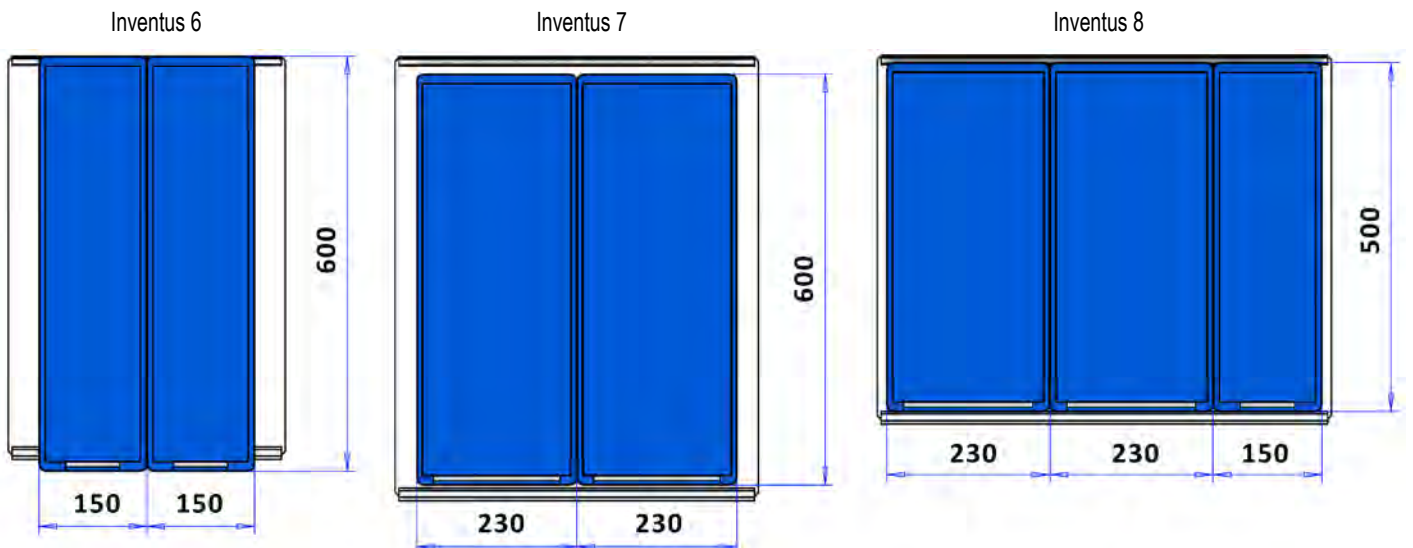

Sales and delivery conditions

1. Prices

Prices are exclusive of VAT. We reserve the right to change prices if the state authorities by changing foreign exchange rates or other charges impact the price determining principles or in case of increase in costs for reasons beyond our control.

2. Deliveries

Terms of delivery is, if not separately agreed, EXW (Ex Works) Ylöjärvi Finland. Standard packaging is included in the prices. If desired, we offer IPPC packaging and freight costs which will be separately priced. Prices do not include waste management arrangements and the cost of recovery of waste. Under the law, the holder of the waste is responsible for the WEEE waste in professional use.

3. Product features

For the purpose of continuous product development, Suomen Kotikylmiö reserves the right to change the products.

4. Changes and cancellations concerning orders

The buyer shall promptly notify in writing the seller of any changes and cancellations. Changes or cancellations must be made fourteen days (14) days before the scheduled delivery time. The seller shall be entitled to invoice the buyer; the value of the current level of preparedness of a product cancelled or changed later than fourteen (14) days. The new delivery time of the changed order will be counted from the date of the change, unless otherwise agreed.

5. Return policy

The seller will not accept returns without prior agreement. The comments regarding the merchandise must be made within five (5) days of receipt. Returns must always be agreed upon in advance with the representative. For the return of standard products, which is not due to the seller's fault, up to 80% will be refunded. Return policy applies only to the products included in the standard sales program with no additional accessories that are unused, undamaged and in their original packaging.

6. Insurance

The customer is responsible for the transportation of goods and transport insurance.

7. Warranty

The warranty period for the raw materials and components is two (2) years if not agreed otherwise. The warranty applies to the equipment sold to the first buyer, i.e. goods have left the factory. The warranty does not cover wear and conditions caused by normal use or the batteries of the appliance. Porkka Finland Oy is not liable for indirect or consequential damages, such as production interruption, product losses, loss of income or other third-party claims.

Warranty is conditional upon the fact that:

- The product is installed in accordance with the provided installation instructions
- The product is used only for its intended purpose
- The product has been used and maintained according to the instructions
- Maintenance work shall be done by a professional refrigeration contractor

Warranty claims must contain:

- Product brand, model and serial number
- Nature of the problem and the circumstances how it has occurred

PORKKA

Porkka Finland Oy is an internationally recognized supplier of professional refrigeration equipment and cold and clean room solutions. Key target areas include hotels and restaurants, food industry, retail, healthcare and research and professional kitchens in the marine industry. Porkka Finland is part of the Finnish Festivo-Porkka Group.

Success of Porkka is based on decades of experience, customer-oriented design and continuous product development. Porkka products are known for their high quality, long life cycle, energy efficiency and sustainable environmental thinking. The materials used in Porkka products are as environmentally friendly and recyclable as possible. Depending on the product group, the recycling rate of products can be even 80 %.



Porkka products are designed and manufactured in accordance with international quality and environmental standards and other regulations. The management system of Porkka is certified according to standards ISO 9001:2015 and ISO 14001:2015.

We reserve the right to make changes without prior notice.

PORKKA FINLAND OY
Huurretie 13, FI-33470 YLÖJÄRVI
sales@porkka.com, www.porkka.com
Tel. +358 (0)10 201 9200

CATERCALL LTD
Aztec House
Unit 8 Perrywood Business Park
Redhill, Surrey RH1 5DZ
porkkaenquiries@catercall.co.uk
Tel. +44 1923 233675

COLIA SCANDINAVIA AB
Industrigatan 21, SE-61933 Trosa
info@colia.se, www.colia.se
Tel. +46 (0)156 348 40

COLIA AS NORWAY
Ringeriksveien 16, NO 3414 Lierstranda
post@colia.no, www.colia.no
Tel. +47 66 98 77 77