

**PORKKA**

HOTEL, RESTAURANT & CATERING  
Chillers, Freezers, Blast chillers, Blast freezers

# Porkka Inventus Cabinets

Professional refrigeration equipment for  
demanding conditions

# We focus to the customer



Our customers are our heart's desire. With our advanced refrigeration and insulation solutions, we help our customers for better business.

## **From one professional to another**

We pass on to our customers the good that our decades of experience and know-how produce. Progress also means learning new and innovating new. It is an attitude that is chosen on a daily basis. We are on our way and our direction is clear. We want to grow into a leading supplier of refrigeration solutions in Northern Europe. For us, the center of everything is the well-being of the customer and their business - now and in the future.



# Inventus product program

Chiller and freezer cabinets – Inventus C, M and F



Inventus 6

Inventus 7

Inventus 7 GW

Inventus C7e

Inventus 8



## Comprehensive product range

The Inventus product range includes chiller and freezer cabinets, blast chillers and blast chillers / blast freezers, as well as various additional functionalities and equipment. The inventory is suitable for professional kitchens, bakeries, hotels, cafes, shops and similar places. It is a solution from professionals to professionals.

## For different operating environments

Professional kitchens and bakeries face different challenges compared to commercial refrigeration equipment. For example, the higher temperature of a commercial kitchen environment requires more performance from refrigeration unit components and insulation panels. Inventus is also an excellent solution for store and café environments.

## Chiller and freezer cabinets for different needs

Chillers are available in three different sizes in three storage temperatures - Inventus C6 / M6, C7 / M7 and C8 / M8. Inventus F6, F7 and F8 are available in the freezers, respectively.

Inventus C7, M7 and F7 cabinets can use GN 2/1 depth shelves, baskets and GN containers or two GN 1/1 containers in a row. Models C8 and F8 can use GN 2/1 wide shelves, baskets and GN containers. The 400x600 shelves and / or baking trays are suitable for the smaller Inventus C6, M6 and F6 models. Inventus uses high-quality stainless steel AISI 304.

## New energy class A cabinets and cabinets with glass windows

Our product range has been supplemented with new Class A Inventus C7e and C8e models. The website [www.topten.eu](http://www.topten.eu) has listed the C7e and C8e models in terms of energy consumption in category A. Use the e-model when you need better energy efficiency!

Inventus C6 / M6 GW, C7 / M7 GW, C8 / M8 GW, F6 GW, F7 GW and F8 GW with glass windows enable excellent product visibility and presentation thanks to the glass window and internal lighting. They are thus suitable for both storage and store furniture.

# Blast Chiller / Blast Chiller/Freezer Cabinets – Inventus BC and BC/BF



Inventus BC 7  
and BC/BF 7



Inventus BC 8  
and BC/BF 8



There is a product temperature sensor inside that can be used to monitor the cooling of a product.

## Masters of blast chilling and blast freezing

Inventus BC 7 and BC 8 control blast cooling. The combination models BC / BF 7 and BC / BF 8 have both blast chilling and blast freezing functions.

The standard programs Soft Chill and Hard Chill for blast chilling, the Soft Freeze and Hard Freeze for blast freezing enable quick start-up. Highly efficient and optimized blast freezing and blast chilling processes are used. In standard programs, after the chilling and freezing processes, the device switches to storage mode.

For temperature self-monitoring (HAACP), all critical data is stored in the devices.

## Sized to fit GN 1/1 containers

All models, ie BC 7, BC 8, BC / BF 7 and BC / BF 8, are dimensioned for GN 1/1 containers. In BC 7 and BC / BF 7, the container is placed widthwise. In the BC 8 and BC / BF 8, the dishes are placed in depth, these models come with 10 pairs of brackets as standard.

## Comprehensive Additional functionalities and accessories

Inventus provides opportunities to connect refrigeration equipment to remote systems. There are many different shelf and leg options available.

## Central cooling (CC) models: R744 (CO<sub>2</sub>) R452A

All Inventus products are also available with central machine connection capability instead of a stand-alone solution.

# Inventus – synonymous with better cabinet

## Benefits and features

For heavy use and demanding conditions

### **1 State-of-the-art usability**

As an example, brackets that prevent the wire rack shelves from tipping over when the shelf is partially pulled out.

### **2 Better hygiene and safety**

Thanks to the cabinet structures, a high level of hygiene is achieved, dirt build-up is prevented and cleaning is as easy as possible. In the door handle sticker and digital control display panel, the Nanoksi Fotonit photocatalytic coating makes the contact surfaces safe to use by destroying harmful microbes. Extended hygiene packages further enhance safety (Nanoksi-Fotonit feature available during late 2021).

### **3 Flexibility and ease**

The product range offers solutions for many needs and a wide range of additional functionalities and accessories are available. Easy to maintain, for example, the door magnetic seal can be replaced without tools.

### **4 Environmentally friendly, future-proof solutions**

High-quality manufacturing and high-quality and long-lasting components. Natural R290 refrigerant. Energy efficient solutions.

### **5 Professionalism in everything**

Decades of knowledge and experience at your disposal.

# HOTEL, RESTAURANT & CATERING

## Chillers, Freezers, Blast chillers, Blast freezers



Nanoksi Fotonit photocatalytic coating is an effective and harmless protection against microbes. It has been proven to destroy viruses, bacteria and mold from all surfaces. The Nano Photonit feature will be available in Inventus products in stages during 2021.



Powerful and productive



Affluent and environmentally conscious



Innovative and modern



Future-proof



Large easy to read digital display, with simple and easy to use with a built-in microprocessor controller.



Moulded anti-tilt shelf supports for increased flexibility and also making sanitising much simpler.



Easy to change pull out / push-in magnetic door gaskets.

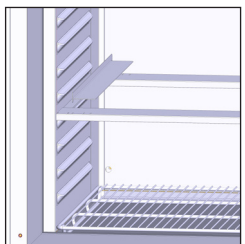

Available as an accessory bakery shelving system enables Inventus 7 - and 8 models for bakery use.



One piece dished floor with rounded corners, avoiding dirt-traps and making spillages easy to clean.



# Inventus C7e and C8e

## More energy efficient models



Inventus C 7e  
Energy efficiency class



### **New Inventus model for best energy efficiency in class A**

Inventus “e” models provide an excellent solution for heavy use in demanding conditions – for professional kitchens, hotels, cafes, shops and similar.

Inventus C 7e and C 8e are new energy-efficient Class A refrigerators. Like all products in the Inventus cabinet family, they are made of high-quality and long-lasting components.

Inventus C 7e and C 8e allow for better energy efficiency when needed. It offers state-of-the-art usability as well as better hygiene and safety. Flexibility and ease are evident in everything. Inventus e-models, like the entire Inventus product family, are designed and manufactured in an environmentally friendly way. It is a future-proof solution where professionalism is visible both as a whole and in small details.

### **Inventus C 7e and C 8e save energy and money**

Table 1 below shows how much money you will save when using the e-model cabinet. Inventus C 7e and C 8e are suitable for applications where better energy efficiency is required. For example, the C 7e consumes only 0.88 kWh / day of electricity (test according to EN 16825). Both the C 7e and C 8e are listed on the website [www.topten.eu](http://www.topten.eu) for energy consumption in category A. Check if your country is covered by the credit system.

### **Additional functionalities and accessories**

Various additional functionalities and accessories such as the Inventus bakery system or wheels instead of legs.

In addition to Inventus e models, the Inventus product range offers solutions for many different needs. The product range covers refrigerated cabinets, freezer cabinets as well as blast chilling and blast chilling / quick freezing solutions.



# HOTEL, RESTAURANT & CATERING

## Chillers, Freezers, Blast chillers, Blast freezers

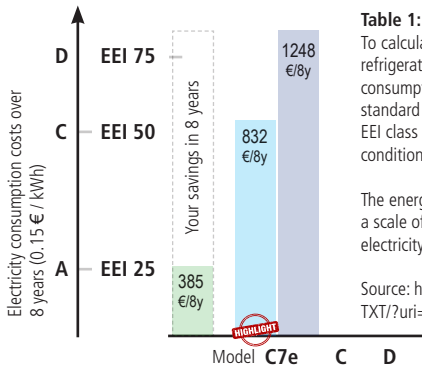

**Table 1:**  
To calculate the energy efficiency index (EEI) of a professional refrigeration or freezer cabinet model, the annual energy consumption of the refrigeration appliance is compared to its standard annual energy consumption. The determination of the EEI class requires laboratory measurements under well-defined conditions.

The energy efficiency of refrigerated storage devices is presented on a scale of A +++ to G. A class A +++ device consumes the least electricity, class G device the most.

Source: <https://eur-lex.europa.eu/legal-content/FI/TXT/?uri=CELEX%3A32015R1094>

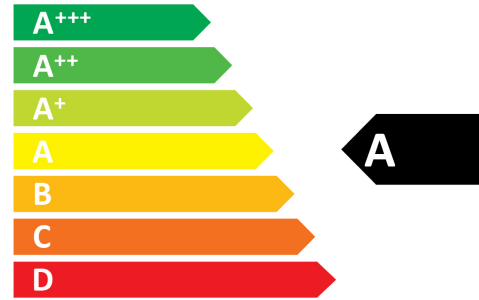

### Features

- Control unit with clear numeric display for temperature and other functions
- Key lock
- Energy class A according to the Ecodesign Directive (Directive 2009/125 / EC)
- Can be connected to a remote system via an optional adapter
- Minimum and maximum temperature recording
- Visual "high temperature" and "low temperature" alarm
- Visual alarm of a broken sensor
- Visual alarm of a clogged condenser
- Door switch for luminaire and fan control and Door open alarm
- The outer surface is made of stainless steel, the inner surface is made of stainless steel (AISI 304 austenitic stainless steel)
- Molded environmentally friendly HFC-free polyurethane insulation
- Four painted wire rack shelves, adjustable in 56 mm increments
- Anti-tilt shelf supports
- Lockable door, tool-free replaceable magnetic seal and durable spring hinges to keep the door open at a 90-degree angle
- Efficient and energy-saving cooling system with R290 refrigerant
- Stainless steel legs, adjustment range 130 mm - 205 mm
- Power supply 230 V / 50 Hz

### Additional functionalities and accessories

- Bakery shelving system
- Nanoksi Fotonit photocatalytic coating, a new innovative self-disinfecting solution for microbial surface protection (coming in 2021)
- Electronic iLOQ locking system
- Stainless steel wire shelf
- Stainless steel panel shelf
- Stainless steel basket shelf
- Wheels instead of legs, two lockable wheels
- Short legs instead of long legs, adjustment range 70 mm - 105 mm
- Foot pedal

### Technical data

INVENTUS		C7e	C8e
Energy efficiency class		A	A
Energy efficiency index (EEI)		23,16	24,20
Energy consumption, 24h (E 24h)	kWh	0,88	0,92
Annual energy consumption	kWh	321	337
Electricity cost in 8 years (0,20/kWh)	EUR	514	540
Volume, gross	dm <sup>3</sup>	609	619
Volume, net	dm <sup>3</sup>	473	474
Climate class		4	4

**This appliance is intended for use in ambient temperatures up to 30 °C**

External width	mm	730	850
External depth	mm	870	750
External height/standard legs	mm	2100	2100
External height/low legs	mm	2050	2050
External height/castors	mm	2080	2080
Internal width	mm	534	654
Internal depth	mm	675	555
Internal height	mm	1485	1485
Weight, gross	kg	162	162
Weight, net	kg	152	152
Shelves (4 pcs), width	mm	531	651
Shelves, depth	mm	660	540
Maximum load / shelf	kg	70	70
Maximum load / cabinet	kg	280	280
Ambient temperature range	°C	+10...+30	+10...+30
Storage temperature range	°C	+1...+12	+1...+12
Nominal power	W	200	200
Cord length	m	3	3
Refrigerant, R290	g	110	110
Fuse, slow	A	10	10
Voltage/Frequency	V/Hz	230/50	230/50
Sound pressure level (1m)	dB(A)	< 50	< 50
Defrost method		Off-cycle	Off-cycle

# Inventus GW

## Models with glass windows



**Inventus C7 GW**  
Model with glass window

### **More durable and better chiller and freezer cabinet with glass windows**

Inventus GW models are an excellent solution for heavy use and demanding conditions in professional kitchens, cafes, hotels, shops and similar places.

Inventus GW models include chiller and freezer upright cabinets with glass windows. Like all cabinets in the Inventus product family, the Inventus GW with glass window is made of high-quality and long-lasting components. It is one example of our advanced cold storage solutions.

### **Inventus GW offer excellent product visibility**

Inventus GW is ideal for both storage and display equipment and enables excellent end-product visibility and presentation. Thanks to the glass window and lighting, display in the store can be done professionally.

It offers state-of-the-art usability as well as better hygiene and safety. Flexibility and ease are evident in everything. Inventus GW, like the entire Inventus product family, is designed and manufactured in an environmentally friendly way. It is a future-proof solution where professionalism is visible both as a whole and in small details.

### **Additional functionalities and accessories for Inventus GW models**

Various additional functionalities and accessories such as the Inventus bakery system or wheels instead of legs.

In addition to the Inventus GW models, the Inventus product range offers solutions for many different needs. The product range covers refrigerated cabinets, freezer cabinets as well as blast chilling and blast chilling / quick freezing solutions.

INVENTUS		C6 GW	C7 GW	C8 GW	M6 GW	M7 GW	M8 GW	F6 GW	F7 GW	F8 GW
Energy efficiency class		<b>D</b>	<b>C</b>	<b>C</b>	<b>D</b>	<b>C</b>	<b>C</b>	<b>D</b>	<b>D</b>	<b>D</b>
Energy efficiency index (EEI)		53,43	39,74	41,82	53,43	39,74	41,82	57,20	53,90	56,60
Energy consumption, 24h (E 24h)	kWh	1,67	1,51	1,59	1,67	1,51	1,59	4,81	5,62	5,91
Annual energy consumption	kWh	610	551	580	610	551	580	1756	2051	2157
Electricity cost in 8 years (0,20/kWh)	EUR	975	882	929	975	882	929	2809	3282	3451
Volume, gross	dm <sup>3</sup>	421	609	619	421	609	619	421	609	619
Volume, net	dm <sup>3</sup>	324	473	474	324	473	474	324	473	474
Climate class		4	4	4	4	4	4	4	4	4

This appliance is intended for use in ambient temperatures up to 30 °C

External width	mm	600	730	850	600	730	850	600	730	850
External depth	mm	760	870	750	760	870	750	760	870	750
External height/standard legs	mm	2100	2100	2100	2100	2100	2100	2100	2100	2100
External height/low legs	mm	2050	2050	2050	2050	2050	2050	2050	2050	2050
External height/castors	mm	2080	2080	2080	2080	2080	2080	2080	2080	2080
Internal width	mm	404	534	654	404	534	654	404	534	654
Internal depth	mm	610	675	555	610	675	555	610	675	555
Internal height	mm	1485	1485	1485	1485	1485	1485	1485	1485	1485
Weight, gross	kg	142	162	162	142	162	162	142	162	162
Weight, net	kg	132	152	152	132	152	152	132	152	152
Shelves (4 pcs), width	mm	400	531	651	400	531	651	400	531	651
Shelves, depth	mm	600	660	540	600	660	540	600	660	540
Maximum load / shelf	kg	70	70	70	70	70	70	70	70	70
Maximum load / cabinet	kg	280	280	280	280	280	280	280	280	280
Ambient temperature range	°C	+10...+30	+10...+30	+10...+30	+10...+30	+10...+30	+10...+30	+10...+30	+10...+30	+10...+30
Storage temperature range	°C	+1...+12	+1...+12	+1...+12	-5...+12	-5...+12	-5...+12	-26...-15	-26...-15	-26...-15
Nominal power	W	320	320	320	320	320	320	440	440	440
Cord length	m	3	3	3	3	3	3	3	3	3
Refrigerant, R290	g	115	110	110	115	110	110	83	90	90
Fuse, slow	A	10	10	10	10	10	10	10	10	10
Voltage/Frequency	V	230/50	230/50	230/50	230/50	230/50	230/50	230/50	230/50	230/50
Sound pressure level (1m)		< 50	< 50	< 50	< 50	< 50	< 50	< 50	< 50	< 50
Defrost method		Off-cycle	Off-cycle	Off-cycle	Hot gas	Hot gas	Hot gas	Hot gas	Hot gas	Hot gas

Central Cooling connection model R452A, R744 (CO <sub>2</sub> )		C6 GW CC	C7 GW CC	C8 GW CC	F6 GW CC	F7 GW CC	F8 GW CC
Weight, gross	kg	132	152	152	132	152	152
Weight, net	kg	122	142	142	122	142	142
Heat extraction rate	W	475	475	475	335	335	335
Evaporation temperature	°C	-10	-10	-10	-28	-28	-28
Maximum allowable pressure PS R452A/R744	Bar	34/60	34/60	34/60	34/60	34/60	34/60
Nominal power	W	110	110	110	450	500	500
Voltage/Frequency	V/Hz	230/50-60	230/50-60	230/50-60	230/50-60	230/50-60	230/50-60
Defrost method		Off-cycle	Off-cycle	Off-cycle	Electrical	Electrical	Electrical

### Additional functionalities and accessories

- Bakery shelf system (C7 and C8, M7 and M8, F7 and F8)
- Electronic iLOQ locking system
- Central machine connection capability also for R744 systems
- Stainless steel wire shelf
- Stainless steel panel shelf
- Stainless steel basket shelf (available for C7, C8, M7, M8, F7 and F8)
- Wheels instead of legs, two lockable
- Short legs instead of long legs, adjustment 70 mm - 105 mm
- Foot pedal

### Features

- Control unit with clear numeric display temperature and other functions
- Key lock
- Glass window door, suitable for both as storage and display furniture
- Can be connected to a remote system as an accessory via the available adapter
- Minimum and maximum temperature recording
- Visual "high temperature" and "low temperature" alarm
- Visual alarm of a broken sensor
- Visual alarm of a blockage from the condenser
- Door switch for light and fan control and the Door open alarm
- The outer surface is made of stainless steel, the inner surface is made of stainless steel (AISI 304 austenitic stainless steel)
- Molded environmentally friendly HFC-free polyurethane insulation
- Four painted wire rack shelves, adjustable in 56 mm increments.
- Anti-tilt shelf supports

- Lockable door, tool-less replaceable magnetic seal and durable spring hinges to keep the door open at a 90-degree angle
- Efficient and energy-saving cooling system with R290 refrigerant
- S stainless steel legs, adjustment range 130 mm - 205 mm
- Power supply 230 V / 50 Hz CC model 230 V / 50-60 Hz

# Inventus C, M and F Chillers and Freezers



Inventus 6



Inventus 7



Inventus 8

### Chiller and freezer cabinets from professionals to professionals

Inventus is a chiller and freezer collection developed for heavy use and demanding conditions. Inventus is synonymous with more durable and better. Professional kitchens and bakeries face different challenges compared to commercial restaurants or shops.

For example, the higher temperature of a commercial kitchen environment requires more performance from refrigeration unit components and insulators. Inventus is also an excellent solution for store and café environments.

The products in the Inventus family are made of high-quality and long-lasting components, and the solutions found in the product range are needed for every need.

### Three sizes: 6, 7, 8 and three storage temperature ranges: C, M, F

Cabinets are available in three different sizes - Inventus C6, M6, C7, M7 and C8, M8. Inventus F6, F7 and F8 are available as freezers, respectively.

Inventus C7, M7 and F7 cabinets can use GN 2/1 depth shelves, baskets and GN containers or two GN 1/1 containers in a row.

Models C8, M8 and F8 can be used with GN 2/1 width shelves, baskets and GN containers. For smaller Inventus C6, M6 and F6 models, shelves and / or baking trays with a size of 400x600 mm are suitable. Inventus cabinets utilize high-quality stainless steel AISI 304.

### Inventus C, M and F benefits

Learn more about the benefits of the Inventus product family on pages 6-7.

### Additional functionalities and accessories for Inventus C, M and F models

Various additional functionalities and accessories can be utilized, such as the Inventus bakery system or, for example, wheels instead of legs.

In addition to the Inventus C, M and F models, the Inventus product range offers solutions for many different needs. A wide range of refrigerators, freezers and blast chillers and blast chillers / blast freezers are available

## Technical data, Chiller cabinets

## Technical data, Freezer cabinets

INVENTUS		C6	C7	C8	M6	M7	M8	F6	F7	F8
Energy efficiency class		<b>B</b>	<b>B</b>	<b>B</b>	<b>B</b>	<b>B</b>	<b>B</b>	<b>C</b>	<b>B</b>	<b>B</b>
Energy efficiency index (EEI)		34,55	32,64	32,61	34,55	32,64	32,61	36,30	31,10	31,10
Energy consumption, 24h (E 24h)	kWh	1,08	1,24	1,24	1,08	1,24	1,24	3,05	3,24	3,24
Annual energy consumption	kWh	394	453	453	394	453	453	1113	1184	1184
Electricity cost in 8 years (0,20/kWh)	EUR	631	724	724	631	724	724	1781	1894	1894
Volume, gross	dm <sup>3</sup>	421	609	619	421	609	619	421	609	619
Volume, net	dm <sup>3</sup>	324	473	474	324	473	474	324	473	474
Climate class		5	5	5	5	5	5	5	5	5

**This appliance is intended for use in ambient temperatures up to 40 °C**

External width	mm	600	730	850	600	730	850	600	730	850
External depth	mm	760	870	750	760	870	750	760	870	750
External height/standard legs	mm	2100	2100	2100	2100	2100	2100	2100	2100	2100
External height/low legs	mm	2050	2050	2050	2050	2050	2050	2050	2050	2050
External height/casters	mm	2080	2080	2080	2080	2080	2080	2080	2080	2080
Internal width	mm	404	534	654	404	534	654	404	534	654
Internal depth	mm	610	675	555	610	675	555	610	675	555
Internal height	mm	1485	1485	1485	1485	1485	1485	1485	1485	1485
Shelves (4 pcs), width	mm	401	531	651	401	531	651	400	531	651
Shelves, depth	mm	600	660	540	600	660	540	600	660	540
Maximum load / shelf	kg	70	70	70	70	70	70	70	70	70
Maximum load / cabinet	kg	280	280	280	280	280	280	280	280	280
Ambient temperature range	°C	+10...+40	+10...+40	+10...+40	+10...+40	+10...+40	+10...+40	+10...+40	+10...+40	+10...+40
Storage temperature range	°C	+1...+12	+1...+12	+1...+12	-5...+12	-5...+12	-5...+12	-26...-15	-26...-15	-26...-15
<b>Plug-in -model:</b>										
Weight, gross	kg	142	162	162	142	162	162	142	162	162
Weight, net	kg	132	152	152	132	152	152	132	152	152
Nominal power	W	300	300	300	300	300	300	420	420	420
Cord length	m	3	3	3	3	3	3	3	3	3
Refrigerant, R290	g	115	110	110	115	110	110	83	90	90
Fuse, slow	A	10	10	10	10	10	10	10	10	10
Voltage/Frequency	V/Hz	230/50	230/50	230/50	230/50	230/50	230/50	230/50	230/50	230/50
Sound pressure level	dB(A)	< 50	< 50	< 50	< 50	< 50	< 50	< 50	< 50	< 50
Defrost method		Off-cycle	Off-cycle	Off-cycle	Hot gas	Hot gas	Hot gas	Hot gas	Hot gas	Hot gas

<b>Central cooling -model R452A, R744 (CO<sub>2</sub>)</b>		<b>C6 CC</b>	<b>C7 CC</b>	<b>C8 CC</b>	<b>F6 CC</b>	<b>F7 CC</b>	<b>F8 CC</b>	<b>Additional functionalities and accessories</b>		
Weight, gross	kg	132	152	152	132	152	152	<ul style="list-style-type: none"> <li>• Bakery shelf system (C7 and C8, M7 and M8, F7 and F8)</li> <li>• Electronic iLOQ locking system</li> <li>• Central machine connection capability also for R744 systems</li> <li>• Stainless steel wire shelf</li> <li>• Stainless steel panel shelf</li> <li>• Stainless steel basket shelf (available for C7, C8, M7, M8, F7 and F8)</li> <li>• Wheels instead of legs, two lockable</li> <li>• Short legs instead of long legs, adjustment 70 mm - 105 mm</li> <li>• Foot pedal</li> </ul>		
Weight, net	kg	122	142	142	122	142	142			
Heat extraction rate	W	450	450	450	310	310	310			
Evaporation temperature	C	-10	-10	-10	-28	-28	-28			
Maximum allowable pressure PS R452A/R744	Bar	34/60	34/60	34/60	34/60	34/60	34/60			
Nominal power	W	100	100	100	440	490	490			
Voltage/Frequency	V/Hz	230/50-60	230/50-60	230/50-60	230/50-60	230/50-60	230/50-60			
Defrost method		Off-cycle	Off-cycle	Off-cycle	Electrical	Electrical	Electrical			

### Features

- Control unit with clear numeric display for temperature and other functions
- Key lock
- Can be connected to a remote system via an optional adapter
- Minimum and maximum temperature recording
- Visual "high temperature" and "low temperature" alarm
- Visual alarm of a broken sensor
- Visual alarm of a clogged condenser
- Door switch for luminaire and fan control and Door open alarm

- The outer surface is made of stainless steel, the inner surface is made of stainless steel (AISI 304 austenitic stainless steel)
- Anti-tilt shelf supports
- Molded environmentally friendly HFC-free polyurethane insulation
- C7, M7 and F7 are dimensioned for GN 2/1 and GN 1/1 containers. In C7, M7 and F7, the vessel is in depth. Instead of one GN 2/1 container, two GN 1/1 containers can be used in succession
- C8, M8 and F8 are dimensioned for GN 2/1 containers. In C8, M8 and F8, the container is widthwise

- Four painted wire rack shelves, adjustable in 56 mm increments
- Lockable door, tool-free replaceable magnetic seal and durable spring hinges to keep the door open at a 90-degree angle
- Efficient and energy-saving cooling system with R290 refrigerant
- Stainless steel legs, adjustment range 130 mm - 205 mm
- Power supply 230 V / 50 Hz

# Inventus Blast Chillers

## BC / BF blast chillers and blast freezers

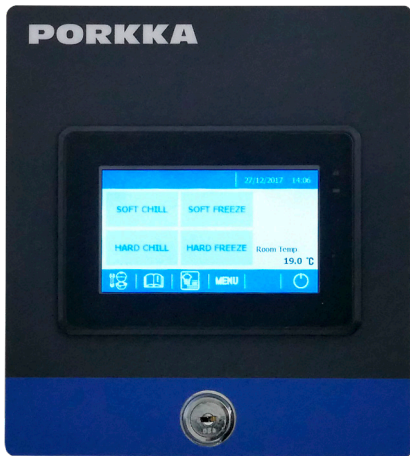

A modern 4.3" color touch screen, an efficient and optimized blast chilling / blast freezing process and ready-made standard programs ensure smooth and fast operation.



**Inventus BC/BF 7**



**Inventus BC/BF 8**

### Masters of blast chilling and freezing

The Inventus BC and BC / BF models are an excellent solution whenever blast chilling or freezing is required. They are designed for heavy use and demanding conditions in professional kitchens, hotels, cafes, shops and similar places.

Inventus BC 7 and BC 8 control blast cooling. The combination models BC / BF 7 and BC / BF 8 have both blast cooling and blast freezing functions. The BC and BC / BF models are made of high-quality and long-lasting components and are the absolute best in the industry. It offers state-of-the-art usability as well as better hygiene and safety. Flexibility and ease are evident in everything.

The BC and BC / BF models are designed and manufactured in an environmentally friendly way. It is a future-proof solution where professionalism is visible both as a whole and in small details.

### Blastly deploy with ready-made standard programs, efficient and optimized processes

Standard programs enable quick commissioning. The BC / BF blast chillers / freezers have four standard programs, Soft Chill, Hard Chill, Soft Freeze and Hard Freeze. There are two of them in BC blast chillers, namely Soft Chill and Hard Chill. Highly efficient and optimized blast-freezing and blast-chilling processes are used. After the two-step process, the device enters storage mode.

For self-monitoring (HAACP), all critical information is stored in the devices.

If you want more flexibility with your own programs, a product sensor as standard. It is possible to make your own programs on the device. If desired, up to a three-step process can be programmed. The evaporator melting cycle can then be defined to be performed before or alternatively after the process. The device can be programmed to finally start the storage mode.

The device comes with a product sensor that is utilized for safe cooling control based on product temperature.

### Rated for GN 1/1 containers

All models, ie BC 7, BC 8, BC / BF 7 and BC / BF 8, are dimensioned for GN 1/1 containers. In BC 7 and BC / BF 7, the container is placed widthwise. The BC 8 and BC / BF 8 are installed in depth, these models always come with 10 pairs of brackets as standard.

### Inventus BC and BC / BF Additional functionalities and accessories

A variety of additional functionalities and accessories are available, such as versatile shelf and leg options. One of the optional options is the UV-C sterilization light, which switches off whenever the door is opened.

In addition to the Inventus BC and BC / BF models, the Inventus product range offers solutions for many different needs. The product range covers refrigerated cabinets, freezer cabinets as well as blast chilling and blast chilling / blast freezing solutions.



An efficient and well-controlled blast chilling and blast freezing process is a guarantee of the high quality of a professional food preparation kitchen. Porkka's step-by-step process ensures healthy and safe manufacturing for schools, kindergartens, workplaces and other locations.

### Features

- Control unit with 4.3 "color touch screen for temperature and other functions
- Advanced quick cooling / quick freezing process
- Storage function
- In BC / BF blast chillers / freezers 4 soft or standard programs Soft Chill, Hard Chill, Soft Freeze and Hard Freeze. In all, a 2-step process, after which the device enters storage mode
- In BC blast chillers 2 quick or soft programs Soft Chill, Hard Chill. In both, a 2-step process, after which the device enters storage mode
- 12 memory slots for your own programs. Possibility to program a 3-stage process, evaporator defrost cycle programmable before or after the process, finally programmable start of storage mode if desired
- Product sensor for safe cooling control based on product temperature
- Can be connected to a remote system
- Recording of self-monitoring and alarm / deviation data
- Audiovisual alerts locally
- Door switch for door open alarm
- The outer surface is made of stainless steel, the inner surface is made of stainless steel (AISI 304 austenitic stainless steel)
- Molded environmentally friendly HFC-free polyurethane insulation
- BC 7, BC 8, BC / BF 7 and BC / BF 8 are dimensioned for GN 1/1 containers. In BC 7 and BC / BF 7, the container is width-wise. In BC 8 and BC / BF 8, the container is in the depth direction, with 10 pairs of brackets as standard
- Anti-tilt shelf supports for GN 1/1 containers
- Tool-free replaceable magnetic seal and durable spring hinges to keep the door open at a 90-degree angle
- Efficient and energy-saving cooling system R452A
- Stainless steel legs, height adjustable from 130 to 205 mm
- Power supply 230 V / 50 Hz

### Additional functionalities and accessories

- UV-C sterilization light that goes out when the door is opened
- Nanoksi Fotonit photocatalytic coating, a new innovative self-disinfecting solution to protect product surfaces from microbes (coming in 2021)
- Central machine connection capability also for R744 systems
- Stainless steel panel shelf
- Wheels instead of legs, two lockable wheels
- Short legs instead of long legs, adjustment margin 70 mm - 105 mm
- Foot pedal

### Technical data

INVENTUS		BC/BF 7	BC/BF 8
Blast chilling capacity*	kg/90min	30	30
Blast freezing capacity**	kg/2,5h	25	25
Internal fittings, Gastronorm		GN 1/1	GN 1/1
Internal fittings, trayslides		19 paria	10 paria
External width	mm	730	850
External depth	mm	870	785
External height/standard legs	mm	2100	2100
External height/castors (plug-in model)	mm	2080	2080
Internal width	mm	530	325
Internal depth	mm	325	570
Internal height	mm	1510	1510
Ambient temperature	°C	+10...32	+10...32
Operating temperature	°C	+90...-20	+90...-20

#### Plug-in model:

Weight, gross	kg	180	180
Weight, net	kg	170	170
Electrical power input	W	2000	2000
Cord length	m	3	3
Refrigerant, R452A	g	1000	1000
Fuse, slow	A	16	16
Voltage/Frequency	V/Hz	230/50	230/50
Sound pressure (1m)	dB(A)	< 65	< 65
Defrost method		Electrical	Electrical

#### Central Cooling model: R744 (CO<sub>2</sub>) and R452A

Weight, gross	kg	146	148
Weight, net	kg	136	138
Heat extraction capacity, BC/BF	W	2500/1200	2500/1200
Evaporation temperature, BC/BF	°C	-15/-30	-15/-30
Max. electrical power input	W	850	850
Sound pressure (1m)	dB(A)	–	–
Defrost method		Electrical	Electrical

\* GN 1/1-65, product thickness 50 mm, initial temperature +70 C, end temperature +3 C

\*\* GN 1/1-65, product thickness 50 mm, initial temperature 0 C, end temperature -18 C

## Bakery Shelf Framing System for Commercial Cabinets

Porkka's new innovative Inventus bakery shelf framing system for our Commercial Cabinets offer ultimate modular versatility for conservation of chilled or frozen bakery products. The bakery shelf framing system is easy to install, easy to use and easy to keep clean.

- Convert easily your Porkka GN 2/1-size cabinet to bakery use
- The shelf frames are easy to remove and keep clean in washing machine
- Shelf frames are designed to keep air-circulation free even when fully loaded
- All generally used baking trays fit to Porkka framing system



### Installation:

1. Place the bakery shelf frame at the desired height in the cabinet.
2. Place the frame guides at the desired width in the shelf frame.
3. If you are using the widest setting for the frame guides, place the frame guides on the shelf frame on the worktop and then place the shelf frame with guides at the desired level in the cabinet.

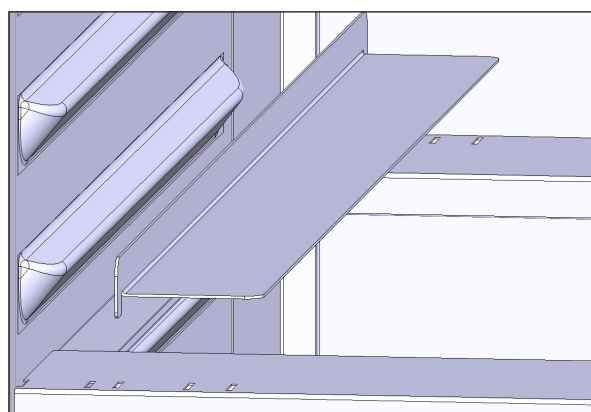

Following shelf widths fits into the Framing System:

### **Inventus 7:**

- 370 / 400 / 450 / 470 / 530 mm
- Max. depth 650 mm

### **Inventus 8:**

- 600 / 650 mm
- Max. depth 530 mm



## Dimensions

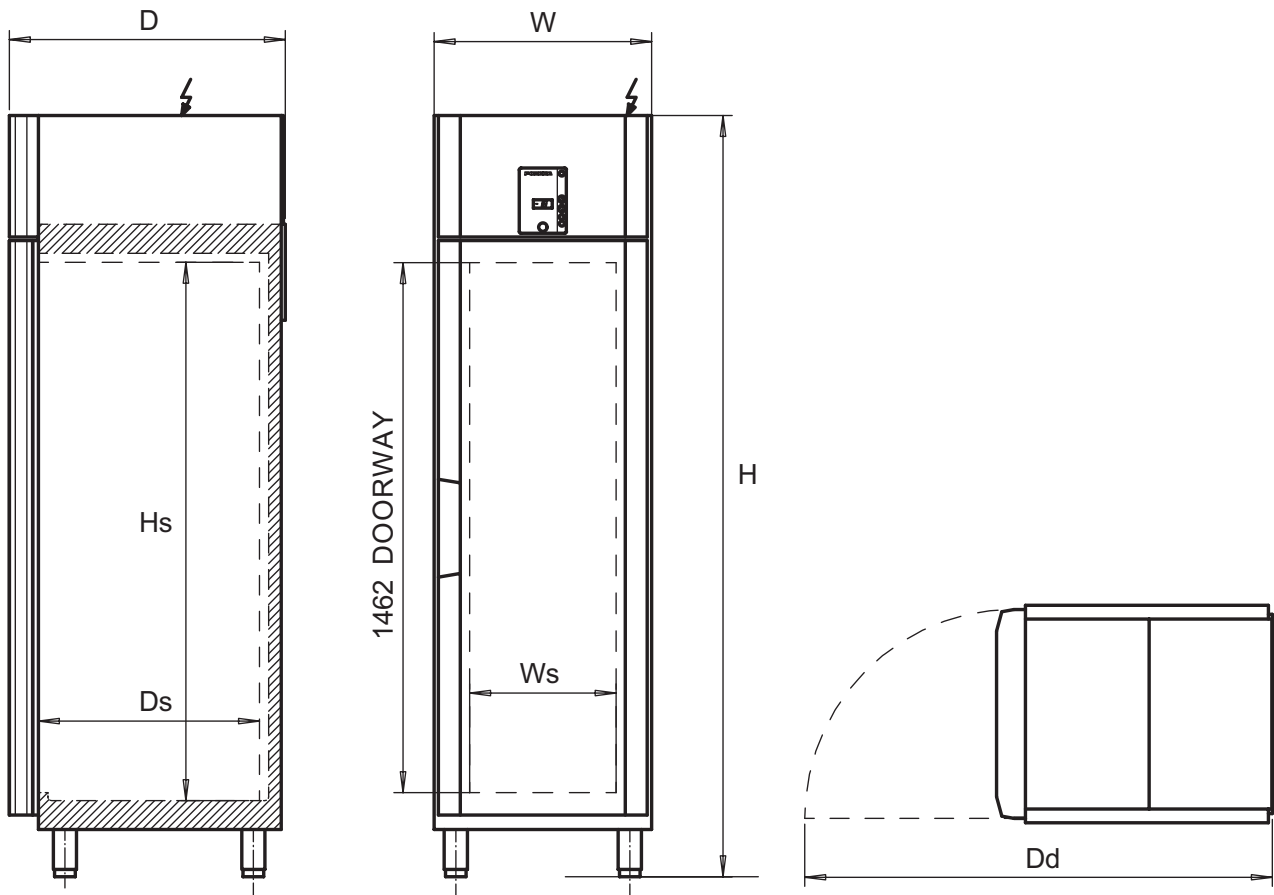

Inventus chiller and freezer cabinets as well as blast chillers and blast freezers

Dimensions (see drawing)			INVENTUS 6	INVENTUS 7	INVENTUS 8	BC/BF 7	BC/BF 8
<b>Outer width</b>	W	mm	600	730	850	730	850
<b>Inner width</b>	Ws	mm	404	534	654	530	325
<b>Outer depth</b>							
• Door closed	D	mm	760	870	750	870	785
• Door opened	Dd	mm	1290	1530	1530	1530	1530
<b>Inner depth</b>	Ds	mm	610	675	555	325	570
<b>Outer height</b>	H	mm					
• Standard legs			2100	2100	2100	2100	2100
• Low legs			2050	2050	2050	2050	2050
• Castors			2080	2080	2080	2080	2080
<b>Inner height</b>	Hs	mm	1485	1485	1485	1485	1485

Porkka is an internationally recognised designer and manufacturer of professional refrigeration solutions. Key target industries include HoReCa, Medical and Research and Marine. Porkka's products are well known on its long life cycle, high quality and technical advantage.

Porkka is a brand of the Festivo-Porkka Group. Porkka brand is well known for its quality and reliability throughout the world. The success of Porkka is based on decades of experience, customer focused design and continuous product development. The materials used in Porkka products are as recyclable and eco-friendly as possible. The recyclability of our product is more than 95%.



Porkka solutions are designed and manufactured according to a quality standard ISO 9001; controlled and certified by Lloyd's Register Quality Assurance. Porkka also hold the environmental certificate ISO 14001:2015, issued also by LRQA. Festivo-Porkka Group reserves the right to make any changes without prior notice.